

Portable Acoustic Sonobuoy Simulator (PASS II)

Portable acoustic test system



Key features

- LCD touch panel display
- Weather resistant
- Convenient travel case
- Supports NATO sonobuoys

Overview

The Portable Acoustic Sonobuoy Simulator II (PASS II) is a test set designed for maritime acoustic system operation verification and laboratory acoustic system integration. It is a field usable electronic transmitter, receiver, and data processor that simulates standard NATO sonobuoys. The PASS II transmitter can also be used to test On Top Position Indicator (OTPI) systems used on aircraft. The PASS II uses a Digital Signal Processor (DSP) to provide signal synthesis for the various supported sonobuoy types. All test signals are developed using a fully digital architecture and used in digital form to modulate the output RF. Digital signals ensure the PASS II provides high fidelity, accurate, artefact-free test signals. Baseband and RF frequencies are generated to within 0.01% of the desired frequency, and FM deviation levels are generated within 0.1% of the desired level.

Technical Specification

Ordering Information

| 6474-0000-001 — PASS II

Applications

Evaluation of acoustic system performance
 Troubleshooting of acoustic suites individual Line Replacement Units (LRUs) - acoustic processor, VHF antenna receiver, UHF downlink
 Acoustic suite health and welfare - pre-flight operational checks
 Bit Error Rate calculation for Flightline wideband sonobuoy receivers
 Signal source to aid in training for technicians and operators
 Sonobuoy support: DICASS, DIFAR, VLAD, LOFAR, BATHYTHERMOGRAPH, HIDAR, BARRA, ADAR, CAMBS
 External PC data streaming
 GPS buoy decoding / simulation

Environmental

Power	115-230 VAC, 50-400 Hz Lithium Ion Battery
Operating Temp	-10°C to 45°C
Storage Temp	-20°C to 45°C
Cooling	N/A
Shock	MIL-STD-810F
Vibration	MIL-STD-810F
Safety Standard	MIL-STD-810F

Included Items

1 PASS II	4 DC Power Cable
2 Self Test Cable	5 UHF Antenna
3 AC Power Cable	6 VHF Antenna

Specification Data

Signal Accuracy

Baseband and RF frequency to 0.01%
 FM deviation level to 0.1%

UHF Downlink

Signal strength: -10 dB

RF Output Parameters

Touch panel input selection of 99 operational sonobuoy frequencies
 VHF signal strength levels generated to 0 dBm (+20 dBm with optional amplifier)
 Direct digital modulation of FSK or GFSK digital sonobuoy types with shaped data for controlled RF spectrum

Interfaces

UHF input to receive and decode UHF command signals from platform's acoustic system
 VHF uplink to transmit VHF signals to a platform acoustic system
 Modulation output for transfer of baseband signals direct to an acoustic processor
 Headphone output for aural monitoring
 Computer and control interfaces include 2 USB (master and remote) and GigE ethernet
 External input for receipt of baseband signals
 UHF output for command downlink

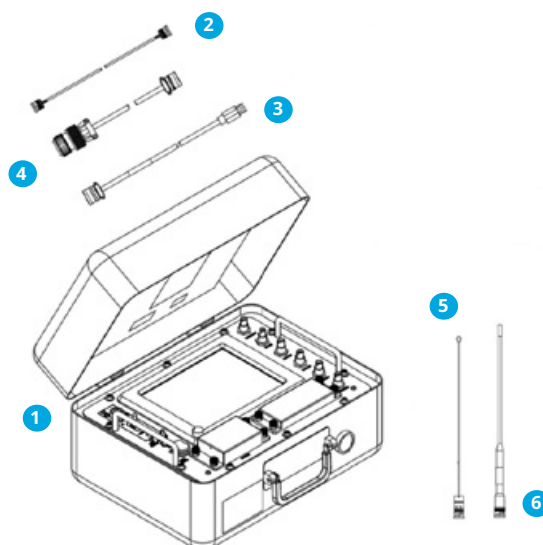

+1 902 466 7491
 sonobuoys@umaritime.com
 umaritime.com

90267A-PDS-PASSII Rev A